

Product data sheet

Characteristics

XMLK100P2D23

Electronic pressure sensors, Pressure sensors XM, sensor XMLK, 0...100 PSI, 1/4NPT, 4...20 mA, M12, set of 1

Product availability: Stock - Normally stocked in distribution facility

Price*: 77.00 USD



Main

Range of product	OsiSense XM
Product or Component Type	Electronic pressure sensors
Pressure sensor type	Pressure transmitter
Pressure sensor name	XMLK
Electrical circuit type	Control circuit
Pressure Rating	100 Psi (689.48 kPa)
Local display	Without
Current Consumption	< 20 mA
Type of output signal	Analogue
Quantity per Set	Set of 1
Type of Packing	Individual

Complementary

Pressure setting range	0...100 Psi (0.00...689.48 kPa)
Maximum permissible accidental pressure	200 Psi (1378.95 kPa)
Destruction pressure	300 Psi (2068.43 kPa)
Materials in contact with fluid	Stainless steel type AISI 303 Nitrile (NBR) Ceramic
Operating position	Any position
Protection Type	Reverse polarity Load short-circuit
[Uimp] rated impulse withstand voltage	0.5 KV
Measurement accuracy	+/- 1 % of the measuring range
Accuracy	0.1 % of the measuring range
Drift of the sensitivity	+/- 0.04 % of measuring range/°K
Drift of the zero point	+/- 0.03 % of measuring range/°K
Repeat accuracy	+/- 1 % of the measuring range
Mechanical durability	10000000 Cycles
Product Weight	0.24 Lb(US) (0.11 kg)

Diameter	1.42 In (36 mm)
Length	2.58 In (65.5 mm)
Scale type	Fixed differential

Environment

Standards	CE EN/IEC 61326-2-3
Product Certifications	CSA C22.2 No 14 RCM EAC UL 508
Protective treatment	TC
Ambient Air Temperature for Operation	32...176 °F (0...80 °C)
Ambient Air Temperature for Storage	-13...176 °F (-25...80 °C)
NEMA degree of protection	NEMA 4

Ordering and shipping details

Category	21561 - XMLK,XMLP PRESSURE TRANSMITTERS
Discount Schedule	DS2
GTIN	3389119048804
Nbr. of units in pkg.	1
Package weight(Lbs)	4.51 Oz (128 g)
Returnability	Yes
Country of origin	CH

Packing Units

Unit Type of Package 1	PCE
Package 1 Height	1.57 In (4 cm)
Package 1 width	6.38 In (16.2 cm)
Package 1 Length	3.23 In (8.2 cm)
Unit Type of Package 2	S01
Number of Units in Package 2	24
Package 2 Weight	7.09 Lb(US) (3.214 kg)
Package 2 Height	5.91 In (15 cm)
Package 2 width	5.91 In (15 cm)
Package 2 Length	15.75 In (40 cm)

Offer Sustainability

California proposition 65	WARNING: This product can expose you to chemicals including: Diisononyl phthalate (DINP), which is known to the State of California to cause cancer, and Diisodecyl phthalate (DIDP), which is known to the State of California to cause birth defects or other reproductive harm. For more information go to www.P65Warnings.ca.gov
REACH Regulation	REACH Declaration
EU RoHS Directive	Pro-active compliance (Product out of EU RoHS legal scope) EU RoHS Declaration
Mercury free	Yes
RoHS exemption information	Yes

Contractual warranty

Warranty	18 months
----------	-----------

Dimensions

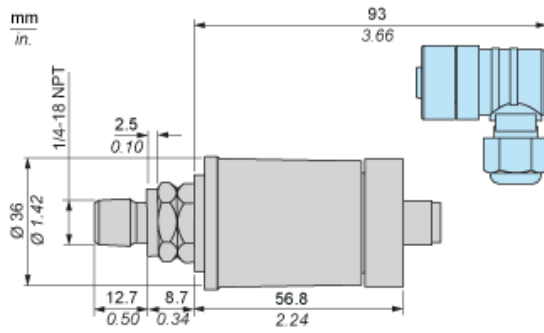

Wiring Diagram

2-Wire Technique (4-20 mA)

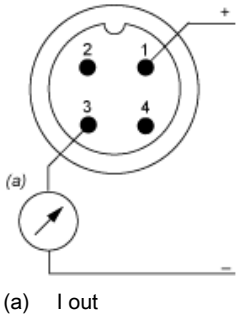

Output Curves

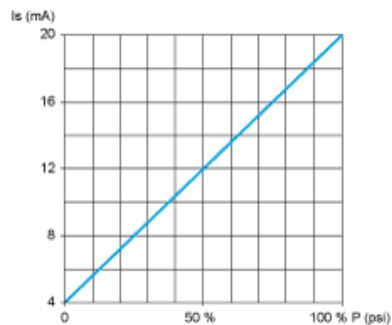

Product Life Status : Commercialised